

Lithium Niobate Fiber Optical Modulator

(30 GHz, 3.5V, bias control option)



DATASHEET

[Return to the Webpage](#)



This series of Lithium Niobate fiber optic modulators use a Mach-Zehnder interferometer structure for optical output power modulation, featuring low operating voltage. It includes a bias control section with an integrated micro-heater and optical power monitor, allowing manual bias adjustment by applying voltage to the heater while monitoring output intensity. An automatic bias control option is available, maintaining $V\pi$ through slow-speed feedback circuitry and compensating DC-drift.

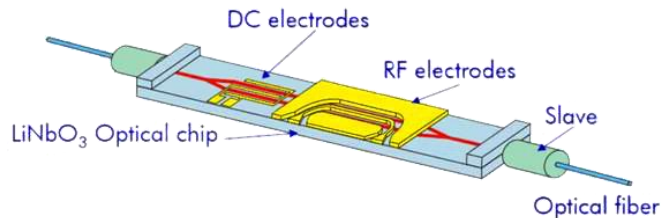

Features

- Low Voltage
- Bias Control
- Feedback

Applications

- Laboratory Uses
- Concept Proving
- Instrumentation

Specifications

Parameter	Min	Typical	Max	Unit
Operation Wavelength	1520		1605	nm
Insertion Loss	4	4.5	5.2	dB
Return Loss	40			dB
Extinction Ratio	16 (H frequency)	20 (H-F)	27 (L frequency)	dB
Optical Input Power			20	mW
RF $V\pi$ Voltage (at 1KHz)		3.5		V
Bandwidth	DC	30	35	GHz
S21 (Electro-Optic Bandwidth-3dB)	10			GHz
S11 (130MHz to 10 GHz)			-10	dB
RF Port Resistance (DC)		50		Ω
RF Input Power			24	dBm
Bias Port Resistance (DC)			1	M Ω
Bias Voltage Range	-15		15	V
Photodetector Responsivity	1			mA/W
Photodetector Extinction Ratio			6	dB
Photodetector Bandwidth		100		kHz
Operating Temperature	-1		70	$^{\circ}$ C
Storage Temperature	-45		85	$^{\circ}$ C

Notes:

Over the maximum power input will burn the device over time

Legal notices: All product information is believed to be accurate and is subject to change without notice. Information contained herein shall legally bind Agiltron only if it is specifically incorporated into the terms and conditions of a sales agreement. Some specific combinations of options may not be available. The user assumes all risks and liability whatsoever in connection with the use of a product or its application.

Rev 01/14/25

Lithium Niobate Fiber Optical Modulator

(30 GHz, 3.5V, bias control option)



DATASHEET

Dimensions (unit: mm – tolerance: 0.2)

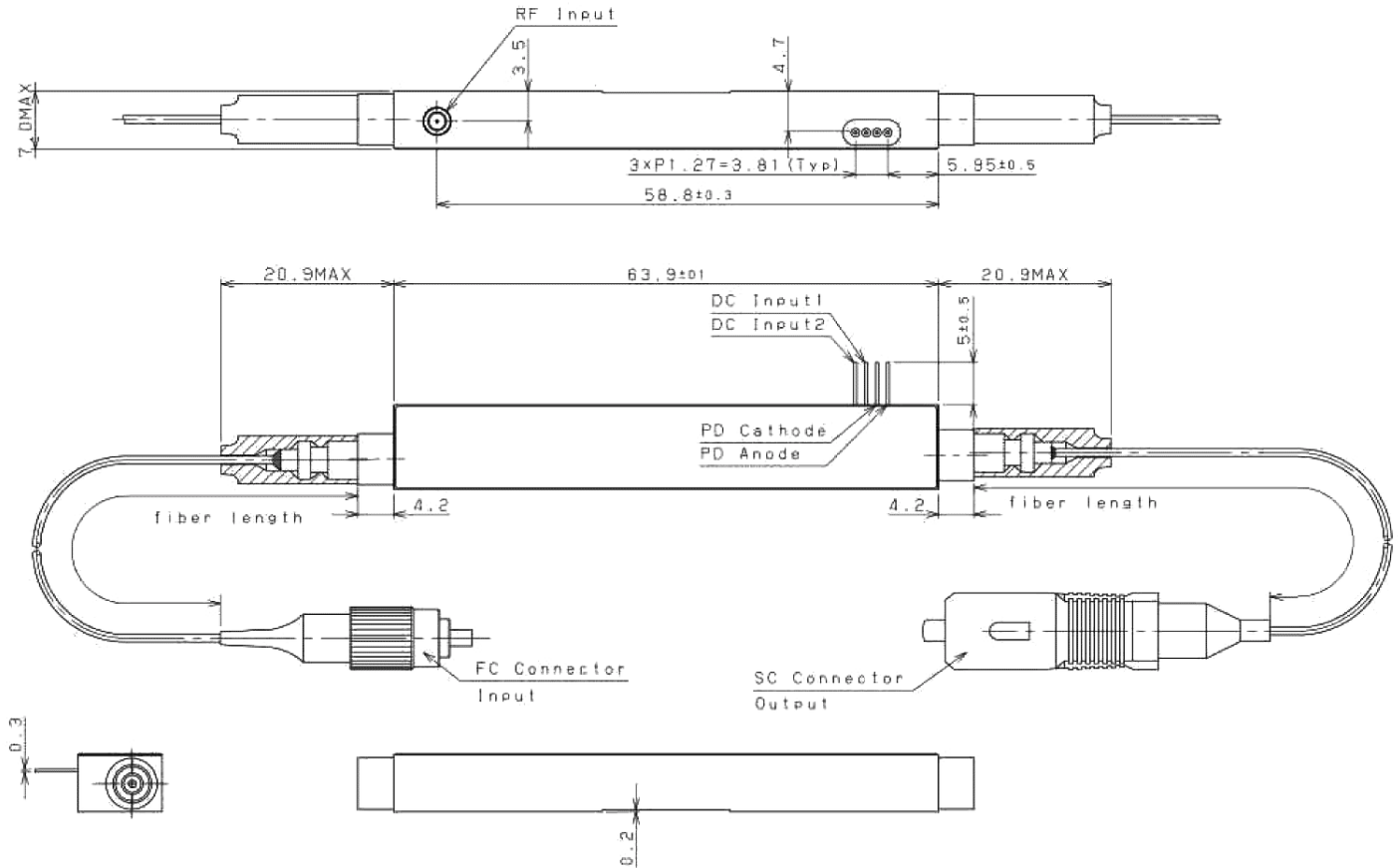

*Product dimensions may change without notice. This is sometimes required for non-standard specifications.

Electrical Connection (RF Input via SMA)

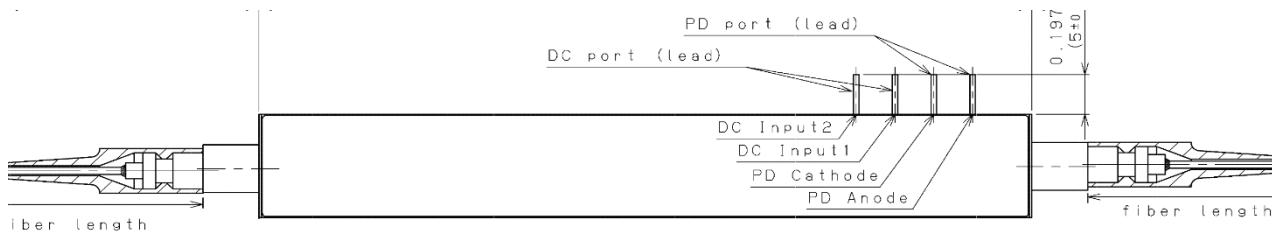

Lithium Niobate Fiber Optical Modulator

(30 GHz, 3.5V, bias control option)



DATASHEET

Ordering Information

Prefix	Configuration	Bias Control	Wavelength	Frequency	Input Fiber	Output Fiber	Cable	Fiber Length	Connector
LNML-	Amplitude = 1	No = 1 Yes = 2	1520-1620nm = 2	30GHz = 3	PM1550 = 5	SMF28e = 1 PM1550 = 5	0.9mm tube = 1 Special = 0	0.5m = 1 Special = 0	None = 1 FC/PC = 2 FC/APC = 3 SC/PC = 4 SC/APC = 5 ST/PC = 6 LC/APC = A LC/UPC = U Special = 0

Performances

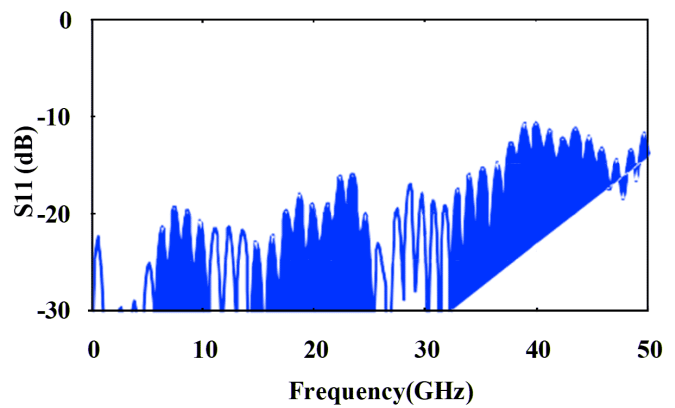
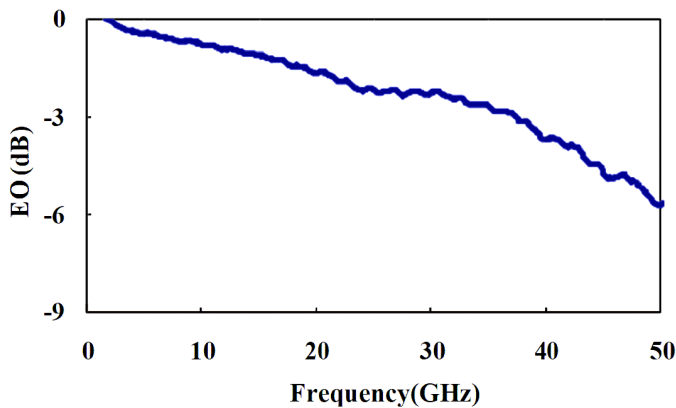

Application Notes

Fiber Core Alignment

Note that the minimum attenuation for these devices depends on excellent core-to-core alignment when the connectors are mated. This is crucial for shorter wavelengths with smaller fiber core diameters that can increase the loss of many decibels above the specification if they are not perfectly aligned. Different vendors' connectors may not mate well with each other, especially for angled APC.

Fiber Cleanliness

Fibers with smaller core diameters (<5 μm) must be kept extremely clean, contamination at fiber-fiber interfaces, combined with the high optical power density, can lead to significant optical damage. This type of damage usually requires re-polishing or replacement of the connector.

Maximum Optical Input Power

Due to their small fiber core diameters for short wavelength and high photon energies, the damage thresholds for device is substantially reduced than the common 1550nm fiber. To avoid damage to the exposed fiber end faces and internal components, the optical input power should never exceed 20 mW for wavelengths shorter 650nm. We produce a special version to increase the how handling by expanding the core side at the fiber ends.

Lithium Niobate Fiber Optical Modulator

(30 GHz, 3.5V, bias control option)



DATASHEET

Typical Circuit

Typical Circuit for Dual-drive

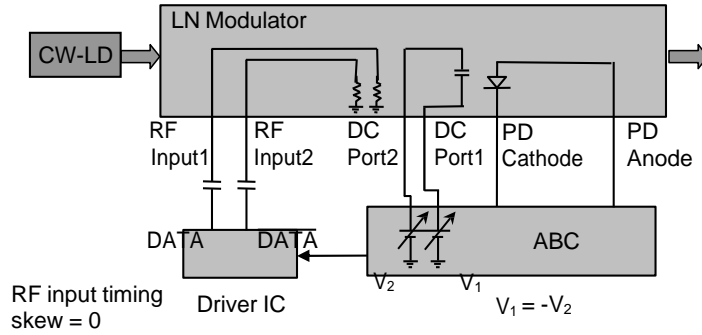

ABC: Automatic Bias Control

Typical Circuit for Single-drive

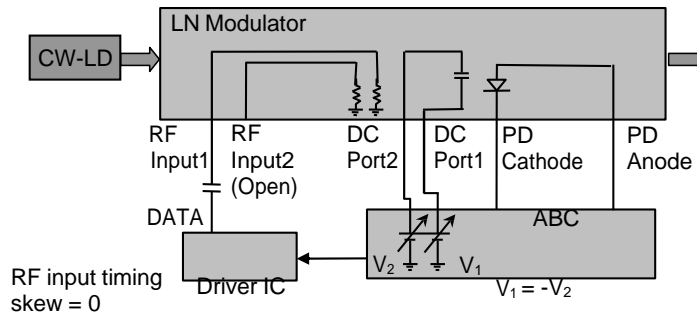

Lithium Niobate Fiber Optical Modulator

(30 GHz, 3.5V, bias control option)



DATASHEET

Benchtop Integration



The EOCV series Fiber Optical Transmitters (Electrical-to-Optical Converters) provide high-fidelity analog and digital optical signals from electrical inputs, supporting a wide frequency range of DC to 10 GHz. These user-friendly turnkey modules integrate a Lithium Niobate Fiberoptic Modulator, a DFB laser with driver, an automatic bias controller, high-performance control circuits, and a DC power supply, into a convenient plug-and-play benchtop unit. The benchtop unit features a front switch to select between three modulator bias modes: Peak and Null for high on/off contrast, and Quadrature for superior linearity in E-O conversion. The laser output power is also adjustable via a front rotating knob, allowing users to fine-tune output settings. Designed for RF-over-Fiber applications, as well as the testing and characterization of optical-to-electrical (O-E) devices, the EOCV series offers a versatile and reliable solution for advanced optical communication and signal processing needs.

Ordering Information

Prefix	RF Frequency	Laser Wavelength*	Tunable Laser	Package	RF Amplifier	Fiber Connector
EOCV-	10GHz = 1	1550 nm = 15500 1551.11 nm = 55111 1562.22 nm = 56222 Special = 00000	None = 1	Benchtop = 3 Special = 0	14dBm gain = 1 Non = 2 Special = 0	FC/APC = 2 Special = 0

Note:

*Laser on the ITU grid can be selected

Information contained herein is deemed to be reliable and accurate as of the issue date. Photonwares reserves the right to change the design or specifications at any time without notice. Agiltron is a registered trademark of Photonwares Corporation in the U.S. and other countries.